

# Introduction to Multiwavelength Optical Networks

**Switching Technology S38.165**  
<http://www.netlab.hut.fi/opetus/s38165>

**Source: Stern-Bala (1999), Multiwavelength Optical Networks**

## Contents

- **The Big Picture**
- Network Resources
- Network Connections

## Optical network

- Why optical networks?
  - “The information superhighway is still a dirt road; more accurately, it is a set of isolated multilane highways with cow paths for entrance.”
- Definition: An **optical network** is a telecommunications network
  - with transmission links that are optical fibers, and
  - with an architecture designed to exploit the unique features of fibers
- Thus, the term optical network (as used here)
  - does not necessarily imply a purely optical network,
  - but it does imply something more than a set of fibers terminated by electronic switches
- The “glue” that holds the purely optical network together consists of
  - optical network nodes (ONN) connecting the fibers within the network
  - network access stations (NAS) interfacing user terminals and other nonoptical end-systems to the network

## Network categories

### **Multiwavelength optical network**

= WDM network

= optical network utilizing wavelength division multiplexing (WDM)

- **Transparent optical network** = purely optical network
  - **Static network** = broadcast-and-select network
  - **Wavelength Routed Network (WRN)**
  - **Linear Lightwave Network (LLN)** = waveband routed network
- **Hybrid optical network** = layered optical network
  - **Logically Routed Network (LRN)**

## Physical picture of the network

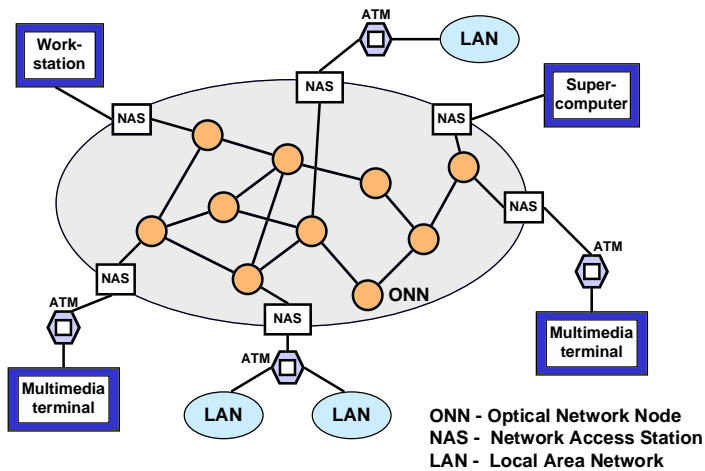

## Wide area optical networks - a wish list

### •Connectivity

- support of a very large number of stations and end systems
- support of a very large number of concurrent connections including multiple connections per station
- efficient support of multi-cast connections

### •Performance

- high aggregate network throughput (hundreds of Tbps)
- high user bit rates (few Gbps)
- small end-to-end delay
- low error rate / high SNR
- low processing load in nodes and stations
- adaptability to changing and unbalanced loads

- efficient and rapid means of fault identification and recovery

### •Structural features

- scalability
- modularity
- survivability (fault tolerance)

### •Technology/cost issues

- access stations: small number of optical transceivers per station and limited complexity of optical transceivers
- network: limited complexity of the optical network nodes, limited number and length of cables and fibers, and efficient use (and reuse) of optical spectrum

## Optics vs. electronics

### Optical domain

- photonic technology is well suited to certain simple (linear) signal-routing and switching functions
    - optical power combining, dividing and filtering
    - wavelength multiplexing, demultiplexing and routing
  - channelizing needed to make efficient use of enormous bandwidth of the fiber
    - by wavelength division multiplexing (WDM)
    - many signals operating on different wavelengths share each fiber
- => optics is fast but dumb  
- **connectivity bottleneck**

### Electrical domain

- electronics is needed to perform more complex (nonlinear) functions
    - signal detection, regeneration and buffering
    - logic functions (e.g. reading and writing packet headers)
  - however, these complex functions limit the throughput
  - electronics also gives a possibility to include in-band control information (e.g. in packet headers)
    - enabling a high degree of virtual connectivity
    - easier to control
- => electronics is slow but smart  
- **electronic bottleneck**

## Optics and electronics

### Hybrid approach:

- a multiwavelength purely optical network as a physical foundation
- one or more logical networks (LN) superimposed on the physical layer, each
  - designed to serve some subset of user requirements and
  - implemented as an electronic overlay
- electronic switching equipment in the logical layer acts as a middleman
  - taking the high-bandwidth transparent channels provided by the physical layer and organizing them into an acceptable and cost-effective form

### Why this hybrid approach ?

- purely optical wavelength selective switches:
  - huge aggregate throughput of few connections
- electronic packet switches:
  - large number of relatively low bit rate virtual connections
- hybrid approach exploits the unique capabilities of optical and electronic switching while circumventing their limitations

## Example LAN interconnection

- Consider a future WAN serving as a backbone that interconnects a large number of high-speed LANs (say 10,000), accessing the WAN through LAN gateways (with aggregate traffic of tens of Tbps)
- Purely optical approach
  - each NAS connects its LAN to the other LAN's through individual optical connections  $\Rightarrow$  9,999 connections per NAS
  - this is far too much for current optical technology
- Purely electronic approach
  - electronics easily supports required connectivity via virtual connections
  - however, the electronic processing bottleneck in the core network does not allow such traffic
- Hybrid approach: both objectives achieved, since
  - LN composed of ATM switches provides the necessary connectivity
  - optical backbone at the physical layer supports the required throughput

## Contents

- The Big Picture
- **Network Resources**
  - **Network Links: Spectrum Partitioning**
  - Layers and Sublayers
  - Optical Network Nodes
  - Network Access Stations
  - Electrical domain resources
- Network Connections

## Network links

A large number of concurrent connections can be supported on each network link through successive levels of **multiplexing**

- **Space division multiplexing** in the fiber layer:
  - a cable consists of several (sometimes more than 100) fibers, which are used as bi-directional pairs
- **Wavelength division multiplexing (WDM)** in the optical layer:
  - a fiber carries connections on many distinct wavelengths ( $\lambda$ -channels)
  - assigned wavelengths must be spaced sufficiently apart to keep neighboring signal spectra from overlapping (to avoid interference)
- **Time division multiplexing (TDM)** in the transmission channel sublayer:
  - a  $\lambda$ -channel is divided (in time) into frames and time-slots
  - each time-slot in a frame corresponds to a transmission channel, which is capable of carrying a logical connection
  - location of a time-slot in a frame identifies a transmission channel

## Fiber resources

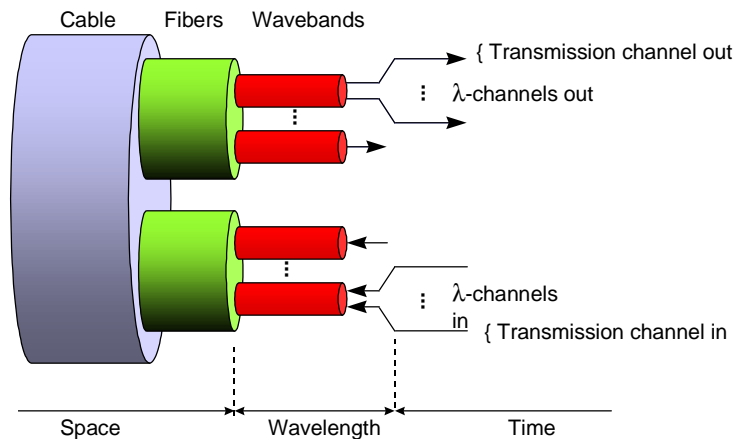

## Optical spectrum

- Since wavelength  $\lambda$  and frequency  $f$  are related by  $f\lambda = c$ , where  $c$  is the velocity of light in the medium, we have the relation

$$\Delta f \approx -\frac{c \Delta \lambda}{\lambda^2}$$

- Thus, 10 GHz  $\approx$  0.08 nm and 100 GHz  $\approx$  0.8 nm in the range of 1,550 nm, where most modern lightwave networks operate
- The 10-GHz channel spacing is sufficient to accommodate  $\lambda$ -channels carrying aggregate digital bit rates on the order of **1 Gbps**
  - modulation efficiency of 0.1 bps/Hz typical for optical systems
- The 10-GHz channel spacing is suitable for optical receivers, but much too dense to permit independent **wavelength routing** at the network nodes
  - for this, 100-GHz channel spacing is needed.
- In a **waveband routing** network, several  $\lambda$ -channels (with 10-GHz channel spacing) comprise an independently routed waveband (with 100-GHz spacing between wavebands).

## Wavelength partitioning of the optical spectrum

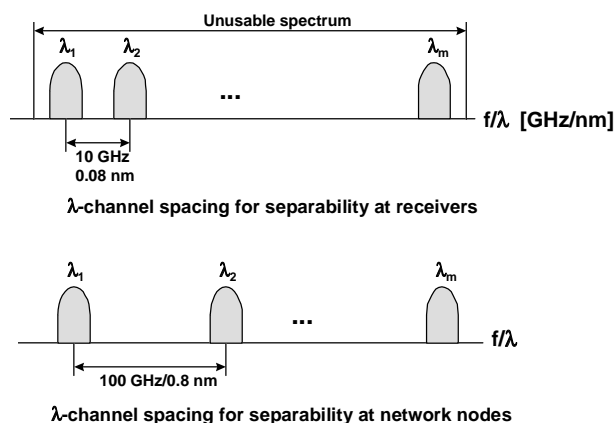

## Wavelength and waveband partitioning of the optical spectrum

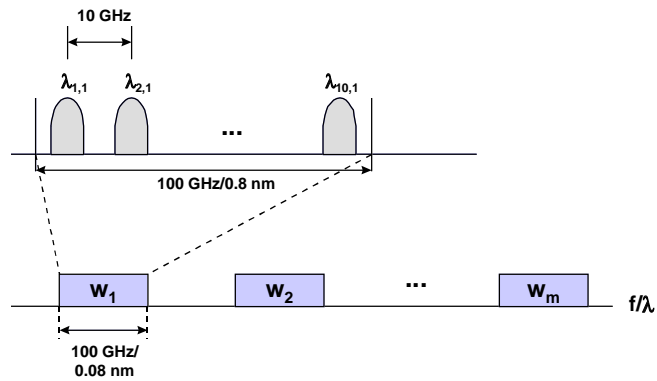

## Network based on spectrum partitioning

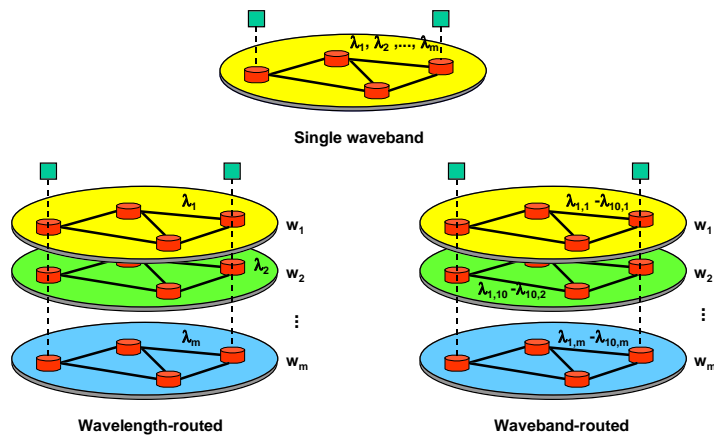



## Contents

- The Big Picture
- **Network Resources**
  - Network Links: Spectrum Partitioning
  - **Layers and Sublayers**
  - Optical Network Nodes
  - Network Access Stations
  - Electrical domain resources
- Network Connections

## Layered view of optical network (1)

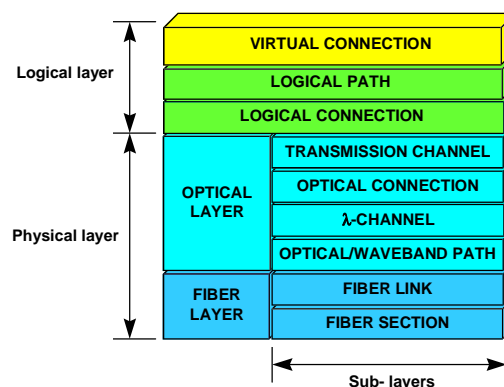

## Layered view of optical network (2)

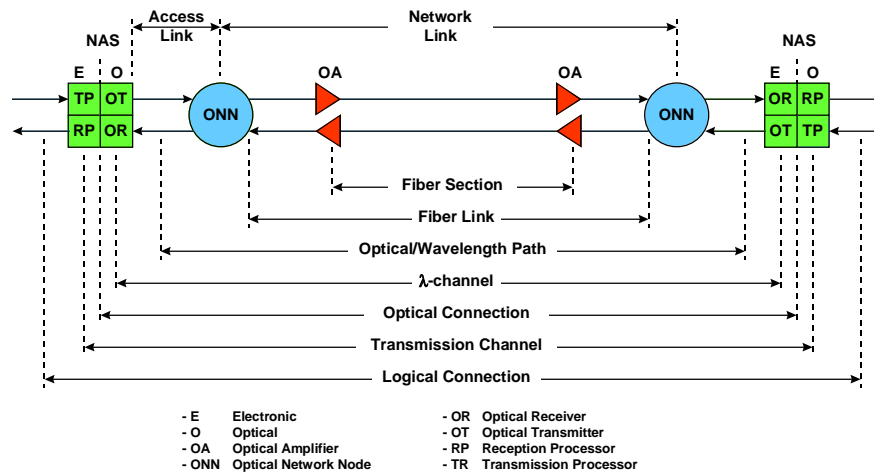

P. Raatikainen

Switching Technology / 2003

11 - 19

## Layers and sublayers

- **Main consideration in breaking down optical layer into sublayers is to account for**
  - multiplexing
  - multiple access (at several layers)
  - switching
- **Using multiplexing**
  - several logical connections may be combined on a  $\lambda$ -channel originating from a station
- **Using multiple access**
  - $\lambda$ -channels originating from several stations may carry multiple logical connections to the same station
- **Through switching**
  - many distinct optical paths may be created on different fibers in the network, using (and reusing)  $\lambda$ -channels on the same wavelength

P. Raatikainen

Switching Technology / 2003

11 - 20

## Typical connection

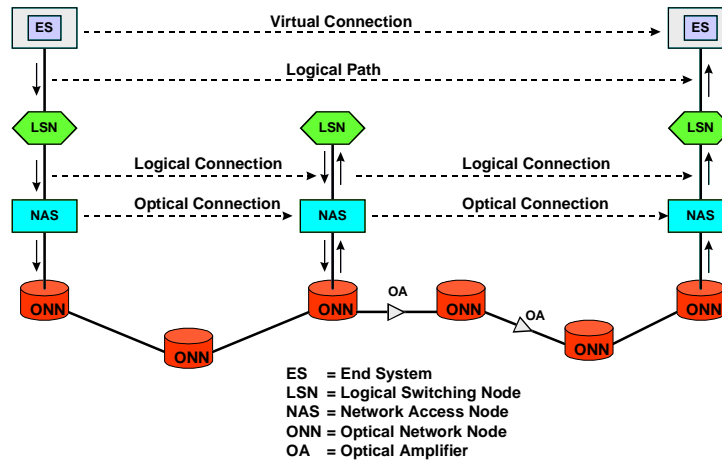

## Contents

- The Big Picture
- **Network Resources**
  - Network Links: Spectrum Partitioning
  - Layers and Sublayers
  - **Optical Network Nodes**
  - Network Access Stations
  - Electrical domain resources
- Network Connections

## Optical network nodes (1)

- **Optical Network Node (ONN)** operates in the optical path sublayer connecting  $N$  input fibers to  $N$  outgoing fibers
- ONNs are in the optical domain

- **Basic building blocks:**

- wavelength multiplexer (WMUX)
- wavelength demultiplexer (WDMUX)
- directional coupler (2x2 switch)
  - static
  - dynamic
- wavelength converter (WC)

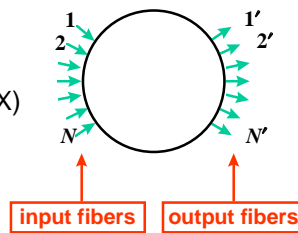

## Optical network nodes (2)

- **Static nodes**

- without wavelength selectivity
  - $N \times N$  **broadcast star** (= star coupler)
  - $N \times 1$  **combiner**
  - $1 \times N$  **divider**
- with wavelength selectivity
  - $N \times N$  **wavelength router** (= Latin router)
  - $N \times 1$  **wavelength multiplexer** (WMUX)
  - $1 \times N$  **wavelength demultiplexer** (WDMUX)

## Optical network nodes (3)

- **Dynamic nodes**

- without wavelength selectivity (optical crossconnect (OXC))
  - NxN **permutation switch**
  - RxN **generalized switch**
  - RxN **linear divider-combiner (LDC)**
- with wavelength selectivity
  - NxN **wavelength selective crossconnect (WSXC)** with M wavelengths
  - NxN **wavelength interchanging crossconnect (WIXC)** with M wavelengths
  - RxN **waveband selective LDC** with M wavebands

## Wavelength multiplexer and demultiplexer

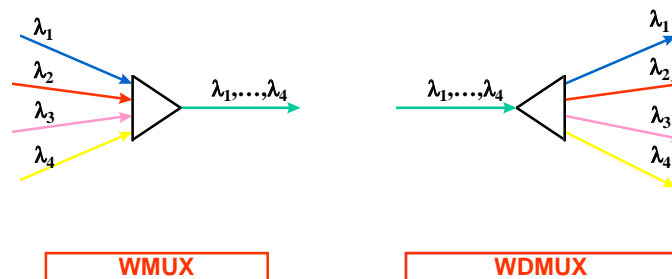

## Directional Coupler (1)

- **Directional coupler** (= 2x2 switch) is an optical four-port
  - ports 1 and 2 designated as input ports
  - ports 1' and 2' designated as output ports
- Optical power
  - enters a coupler through fibers attached to input ports,
  - divided and combined **linearly**
  - leaves via fibers attached to output ports
- Power relations for input signal powers  $P_1$  and  $P_2$  and output powers  $P_{1'}$  and  $P_{2'}$  are given by

$$P_{1'} = a_{11}P_1 + a_{12}P_2$$

$$P_{2'} = a_{21}P_1 + a_{22}P_2$$

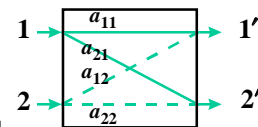

- Denote the **power transfer matrix** by  $A = [a_{ij}]$

## Directional Coupler (2)

- Ideally, the power transfer matrix  $A$  is of the form

$$A = \begin{bmatrix} 1-\alpha & \alpha \\ \alpha & 1-\alpha \end{bmatrix}, \quad 0 \leq \alpha \leq 1$$

- If parameter  $\alpha$  is fixed, the device is **static**, e.g. with  $\alpha = 1/2$  and signals present at both inputs, the device acts as a 2x2 star coupler
- If  $\alpha$  can be varied through some external control, the device is **dynamic** or controllable, e.g. add-drop switch
- If only input port 1 is used (i.e.,  $P_2 = 0$ ), the device acts as a 1x2 **divider**
- If only output port 1' is used (and port 2' is terminated), the device acts as a 2x1 **combiner**

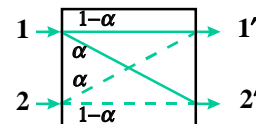

## Add-drop switch

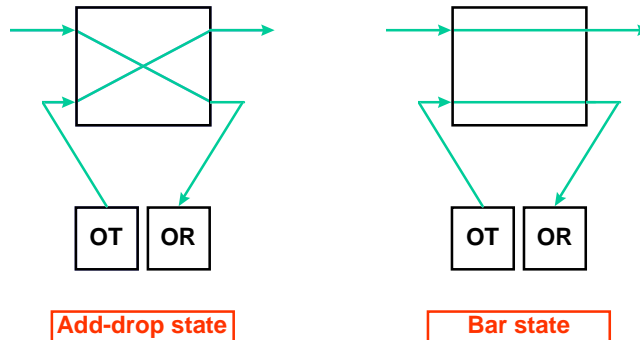

P. Raatikainen

Switching Technology / 2003

11 - 29

## Broadcast star

- Static  $N \times N$  **broadcast star** with  $N$  wavelengths can carry
  - $N$  simultaneous **multi-cast** optical connections (= full multipoint optical connectivity)
- Power is divided uniformly
- To avoid collisions each input signal must use different wavelength
- Directional coupler realization
  - $(N/2) \log_2 N$  couplers needed

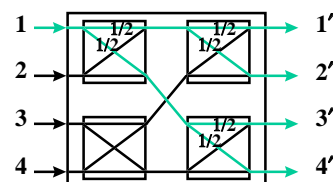
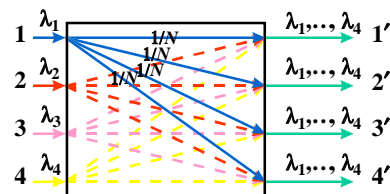

**broadcast star realized by directional couplers**

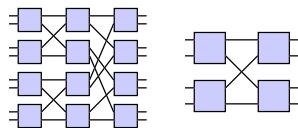

P. Raatikainen

Switching Technology / 2003

11 - 30

## Wavelength router

- Static  $N \times N$  **wavelength router** with  $N$  wavelengths can carry
  - $N^2$  simultaneous **unicast** optical connections (= full point-to-point optical connectivity)
- Requires
  - $N$   $1 \times N$  WDMUX's
  - $N$   $N \times 1$  WMUX's

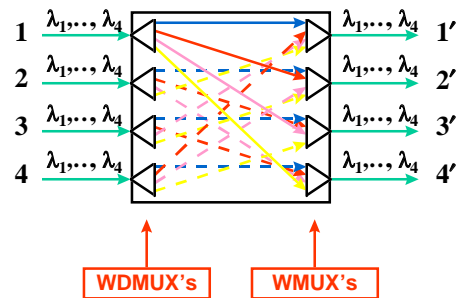

## Crossbar switch

- Dynamic  $R \times N$  **crossbar switch** consists of
  - $R$  input lines
  - $N$  output lines
  - $RN$  crosspoints
- Crosspoints implemented by **controllable** optical couplers
  - $RN$  couplers needed
- A crossbar can be used as
  - a  $N \times N$  **permutation switch** (then  $R = N$ ) or
  - a  $R \times N$  **generalized switch**

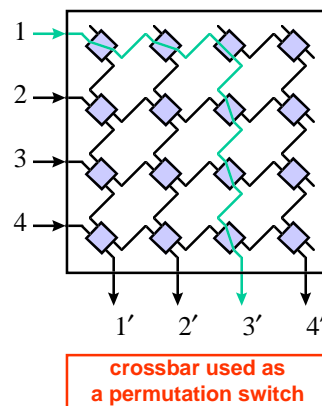



## Permutation switch

- Dynamic  $N \times N$  **permutation switch** (e.g. crossbar switch)

- unicast optical connections between input and output ports
- $N!$  **connection states** (if nonblocking)
- each connection state can carry  $N$  simultaneous unicast optical connections
- representation of a connection state by a  $N \times N$  **connection matrix**

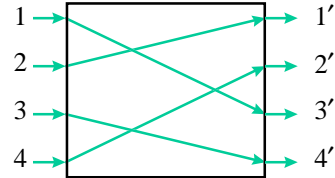

		output ports			
		1'	2'	3'	4'
input ports	1			1	
	2	1			
	3				1
	4		1		

## Generalized switch

- Dynamic  $R \times N$  **generalized switch** (e.g. crossbar switch)

- any input/output pattern possible
- $2^{NR}$  **connection states**
- each connection state can carry (at most)  $R$  simultaneous multicast optical connections
- a connection state represented by a  $R \times N$  **connection matrix**

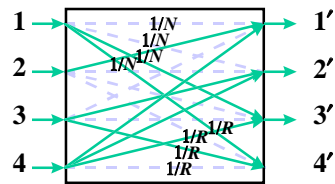

		output ports			
		1'	2'	3'	4'
input ports	1			1	1
	2	1			
	3		1		1
	4	1	1	1	

- Input/output power relation  $P' = AP$  with  $N \times R$  power transfer matrix  $A = [a_{ij}]$ , where

$$a_{ij} = \begin{cases} \frac{1}{NR}, & \text{if switch } (i,j) \text{ is on} \\ 0, & \text{otherwise} \end{cases}$$

## Linear Divider-Combiner (LDC)

- **Linear Divider-Combiner (LDC)** is a generalized switch that
  - controls power-dividing and power-combining ratios
  - less inherent loss than in crossbar
- Power-dividing and power-combining ratios
  - $\delta_{ij}$  = fraction of power from input port  $j$  directed to output port  $i'$
  - $\sigma_{ij}$  = fraction of power from input port  $j$  combined onto output port  $i$
- In an ideal case of lossless couplers, we have constraints

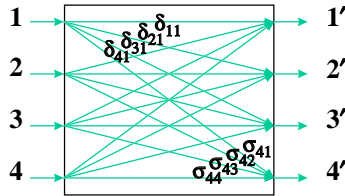

$$\sum_i \delta_{ij} = 1 \quad \text{and} \quad \sum_j \sigma_{ij} = 1$$

- The resulting power transfer matrix  $A = [a_{ij}]$  is such that

$$a_{ij} = \delta_{ij} \sigma_{ij}$$

## LDC and generalized switch realizations

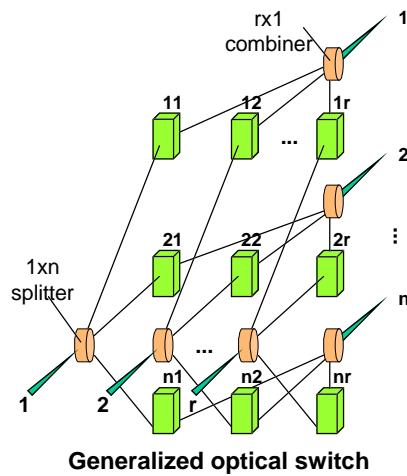
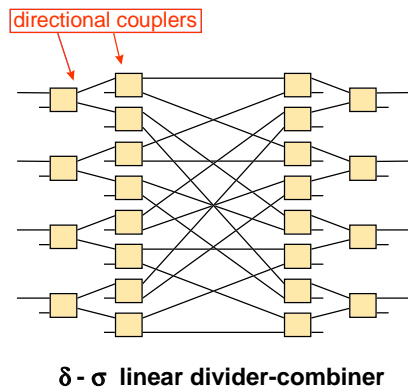

## Wavelength selective cross-connect (WSXC)

- Dynamic NxN **wavelength selective crossconnect** (WSXC) with M wavelengths

- includes N 1xM WDMUXs, M NxN permutation switches, and N Mx1 WMUXs
- $(N!)^M$  connection states if the permutation switches are nonblocking
- each connection state can carry NM simultaneous unicast optical connections
- representation of a connection state by M NxN **connection matrices**

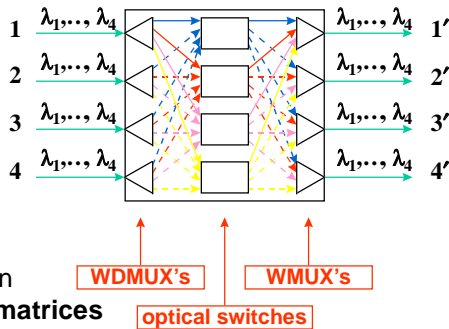

## Wavelength interchanging cross-connect (WIXC)

- Dynamic NxN **wavelength interchanging crossconnect** (WIXC) with M wavelengths

- includes N 1xM WDMUXs, 1 NM x NM permutation switch, NM WCs, and N Mx1 WMUXs
- $(NM)!$  connection states if the permutation switch is nonblocking
- each connection state can carry NM simultaneous unicast connections
- representation of a connection state by a  $NM \times NM$  **connection matrix**

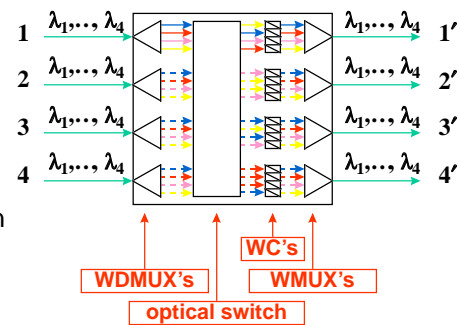

## Waveband selective LDC

- Dynamic RxN **waveband selective LDC** with M wavebands
  - includes R 1xM WDMUXs, M RxN LDCs, and N Mx1 WMUXs
  - $2^{RNM}$  connection states (if used as a generalized switch)
  - each connection state can carry (at most) RM simultaneous multi-cast connections
  - representation of a connection state by a M RxN **connection matrices**

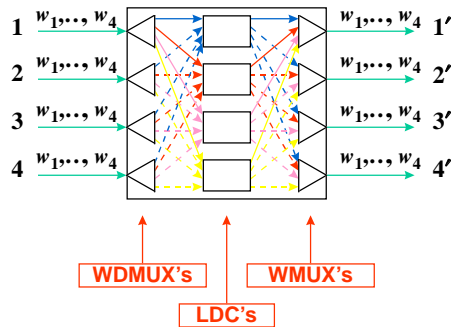

## Contents

- The Big Picture
- **Network Resources**
  - Network Links: Spectrum Partitioning
  - Layers and Sublayers
  - Optical Network Nodes
  - **Network Access Stations**
  - Electrical domain resources
- Network Connections

## Network access stations (1)

- **Network Access Station (NAS)** operates in the logical connection, transmission channel and  $\lambda$ -channel sublayers
- NASs are the gateways between the electrical and optical domains

- **Functions:**

- interfaces the external LC ports to the optical transceivers
- implements the functions necessary to move signals between the electrical and optical domains

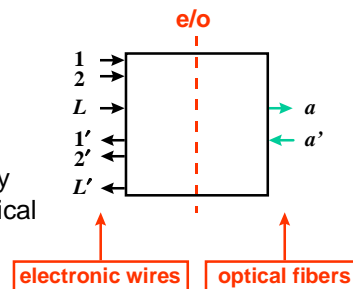

## Network access stations (2)

- **Transmitting side** components:

- **Transmission Processor (TP)** with a number of LC input ports and transmission channel output ports connected to optical transmitters (converts each logical signal to a transmission signal)
- **Optical Transmitters (OT)** with a laser modulated by transmission signals and connected to a WMUX (generates optical signals)
- **WMUX** multiplexes the optical signals to an outbound access fiber

- **Receiving side** components:

- **WDMUX** demultiplexes optical signals from an inbound access fiber and passes them to optical receivers
- **Optical Receivers (OR)** convert optical power to electrical transmission signals, which are corrupted versions of the original transmitted signals
- **Reception Processor (RP)** converts the corrupted transmission signals to logical signals (e.g. regenerating digital signals)

## Elementary network access station

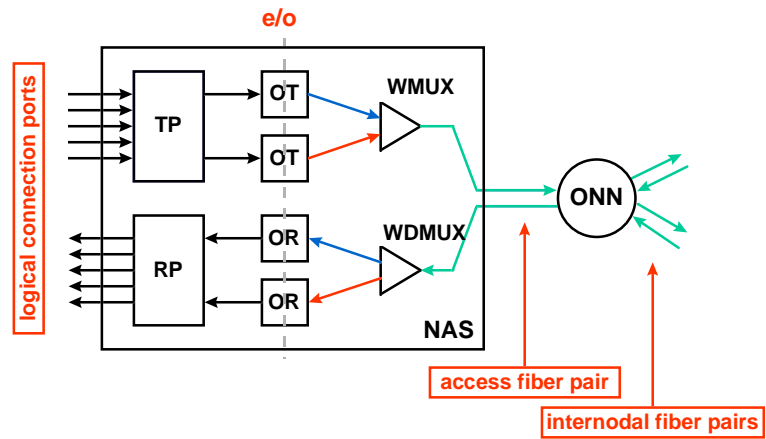

## Nonblocking network access station

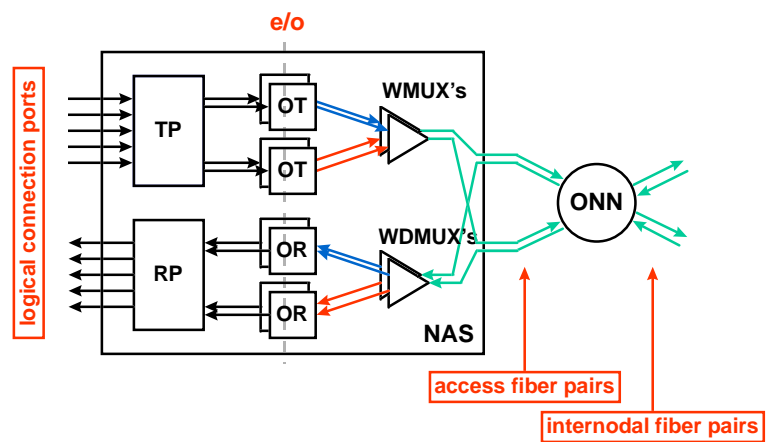

## Wavelength add-drop multiplexer (WADM)

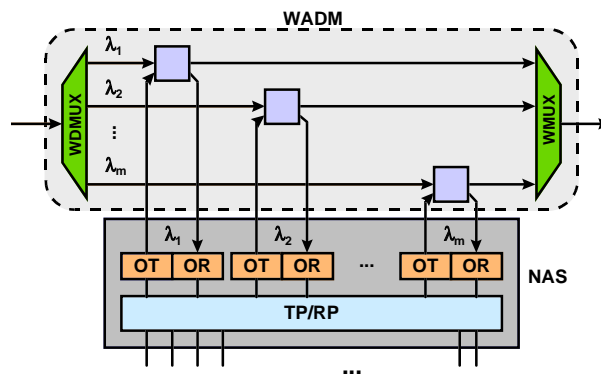

## Contents

- The Big Picture
- **Network Resources**
  - Network Links: Spectrum Partitioning
  - Layers and Sublayers
  - Optical Network Nodes
  - Network Access Stations
  - **Electrical domain resources**
- Network Connections

## End System

- **End systems** are in the electrical domain
- In transparent optical networks, they are directly connected to NASs
  - purpose is to create full logical connectivity between end stations
- In hybrid networks, they are connected to LSNs
  - purpose is to create full virtual connectivity between end stations

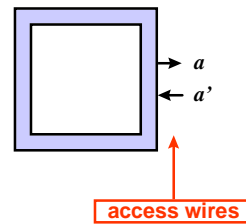

## Logical Switching Node (LSN)

- **Logical switching nodes** (LSN) are needed in hybrid networks, i.e. **logically routed networks** (LRN)
- LSNs are in the electrical domain
- They may be e.g.
  - SONET digital cross-connect systems (DCS), or
  - ATM switches, or
  - IP routers

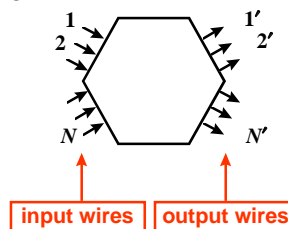



## Logically routed network

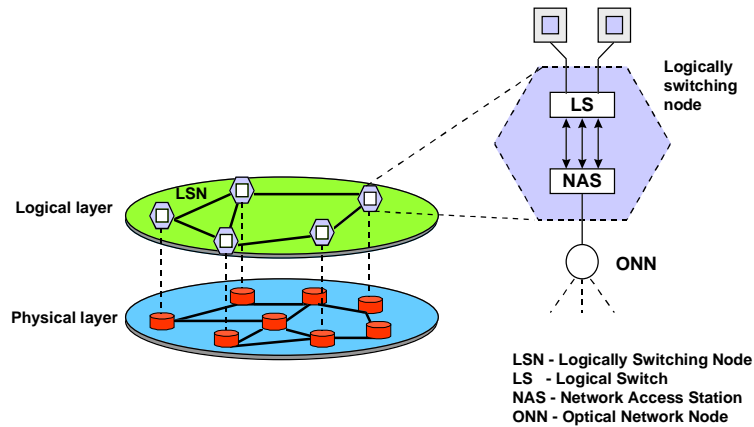

## Contents

- The Big Picture
- Network Resources
- **Network Connections**
  - **Connectivity**
  - Connections in various layers
  - Example: realizing full connectivity between five end systems

## Connectivity

- **Transmitting side:**

- **one-to-one**
  - (single) unicast
- **one-to-many**
  - multiple unicasts
  - (single) multicast
  - multiple multicasts

- **Receiving side:**

- **one-to-one**
  - (single) unicast
  - (single) multicast
- **many-to-one**
  - multiple unicasts
  - multiple multicasts

- **Network wide:**

- point-to-point
- multipoint

## Connection Graph (CG)

- Representing **point-to-point** connectivity between end systems

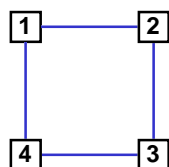

Connection graph

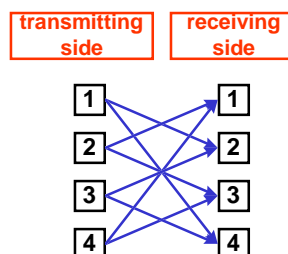

Bipartite representation

## Connection Hypergraph (CH)

- Representing **multipoint** connectivity between end systems

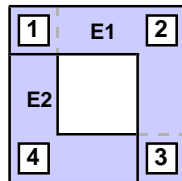

Connection hypergraph

transmitting side   hyper-edges   receiving side

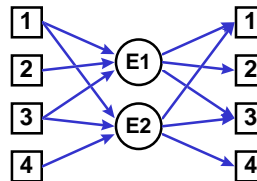

Tripartite representation

## Contents

- The Big Picture
- Network Resources
- **Network Connections**
  - Connectivity
  - **Connections in various layers**
  - Example: realizing full connectivity between five end systems

## Connections in various layers

- **Logical connection** sublayer
  - Logical connection (LC) is a unidirectional connection between external ports on a pair of source and destination network access stations (NAS)
- **Optical connection** sublayer
  - Optical connection (OC) defines a relation between one transmitter and one or more receivers, all operating in the same wavelength
- **Optical path** sublayer
  - Optical path (OP) routes the aggregate power on one waveband on a fiber, which could originate from several transmitters within the waveband

## Notation for connections in various layers

- **Logical connection** sublayer
  - $[a, b]$  = point-to-point logical connection from an external port on station  $a$  to one on station  $b$
  - $[a, \{b, c, \dots\}]$  = multi-cast logical connection from  $a$  to set  $\{b, c, \dots\}$ 
    - station  $a$  sends the *same* information to all receiving stations
- **Optical connection** sublayer
  - $(a, b)$  = point-to-point optical connection from station  $a$  to station  $b$
  - $(a, b)_k$  = point-to-point optical connection from  $a$  to  $b$  using wavelength  $\lambda_k$
  - $(a, \{b, c, \dots\})$  = multi-cast optical connection from  $a$  to set  $\{b, c, \dots\}$
- **Optical path** sublayer
  - $\langle a, b \rangle$  = point-to-point optical path from station  $a$  to station  $b$
  - $\langle a, b \rangle_k$  = point-to-point optical path from  $a$  to  $b$  using waveband  $w_k$
  - $\langle a, \{b, c, \dots\} \rangle$  = multi-cast optical path from  $a$  to set  $\{b, c, \dots\}$

## Example of a logical connection between two NASs

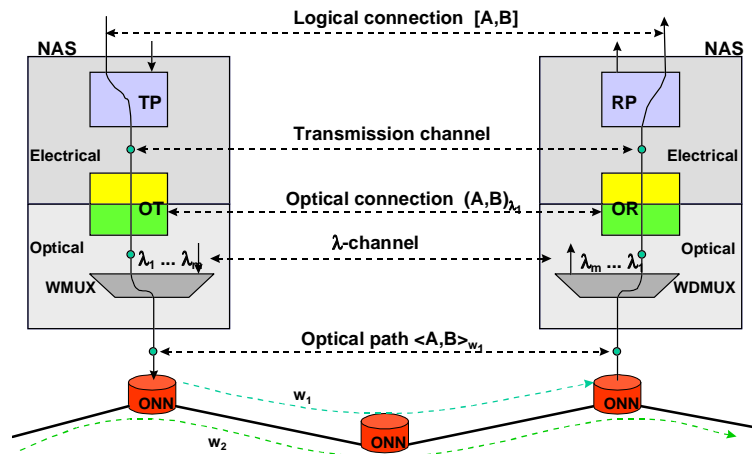

## Contents

- The Big Picture
- Network Resources
- **Network Connections**
  - Connectivity
  - Connections in various layers
  - **Example: realizing full connectivity between five end systems**

## Example: realization of full connectivity between 5 end systems

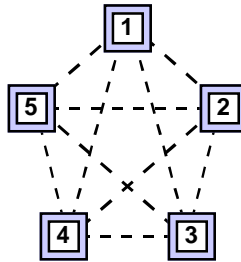

## Solutions

- **Static network** based on star physical topology
  - full connectivity in the logical layer (20 logical connections)
  - 4 optical transceivers per NAS, 5 NASs, 1 ONN (broadcast star)
  - 20 wavelengths for max throughput by WDM/WDMA
- **Wavelength routed network (WRN)** based on bi-directional ring physical topology
  - full connectivity in the logical layer (20 logical connections)
  - 4 optical transceivers per NAS, 5 NASs, 5 ONNs (WSXCs)
  - 4 wavelengths (assuming elementary NASs)
- **Logically routed network (LRN)** based on star physical topology and unidirectional ring logical topology
  - full connectivity in the virtual layer but only partial connectivity in the logical layer (5 logical connections)
  - 1 optical transceiver per NAS, 5 NASs, 1 ONN (WSXC), 5 LSNs
  - 1 wavelength

## Static network realization

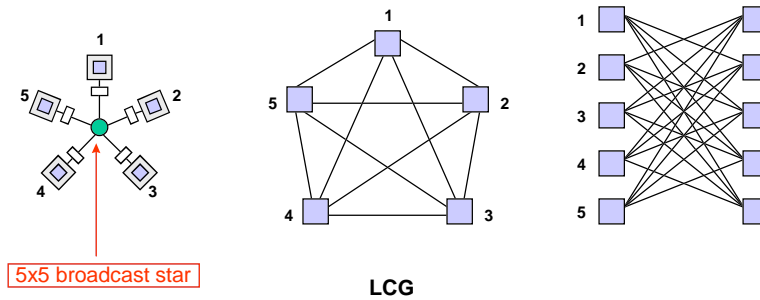

P. Raatikainen

Switching Technology / 2003

11 - 61

## Wavelength routed network realization

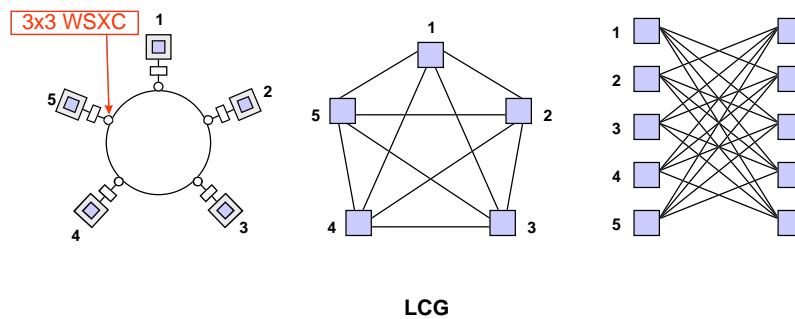

P. Raatikainen

Switching Technology / 2003

11 - 62

# Logically routed network realization

